



# VAPOR LIQUID EQUILIBRIUM DATA GENERATION FOR ACETIC ACID AND p-XYLENE AT ATMOSPHERIC PRESSURE

PAWAN KIRAN MALI<sup>\*,a</sup> and PRAKASH V. CHAVAN<sup>b</sup>

<sup>a</sup>Department of Chemical Technology, Bharati Vidyapeeth Deemed University,  
College of Engineering, PUNE (M.S.) INDIA

<sup>b</sup>Department of Chemical Engineering, Bharati Vidyapeeth Deemed University,  
College of Engineering, PUNE (M.S.) INDIA

## ABSTRACT

In the present study, vapor liquid equilibrium data (VLE) has been generated for binary system: acetic acid and p-xylene, at atmospheric pressure (96.15 Kpa). The recirculation type of apparatus was used for generating the VLE data for a given temperature and compositions<sup>1</sup>. The activity coefficients were estimated using Wilson and NRTL models at different composition. It has been seen that experimental data fits well to the predicted data. Further, thermodynamic consistency of experimental data has been confirmed using Redlich- Kister and point to point test methods. It has been found that experimental data is thermodynamically consistent.

**Key words:** VLE, WILSON, NRTL, Acetic acid, p-Xylene, Binary interaction parameters, Thermodynamic consistency.

## INTRODUCTION

Acetic acid and p-xylene are used for manufacturing of the terephthalic acid<sup>1</sup>, which is primarily used as the raw material for manufacturing of polyester, a polymer used to make the variety of household items such as plastic bottles and other plastic items used in day to day life. The liquid stream generated in the manufacturing of terephthalic acid usually contains acetic acid and p- xylene pair. It is imperative to separate acetic acid from p-xylene for reuse. Distillation is commonly exercised for separation. However, the rational design of the distillation column needs VLE data, which determines the extent of purity of compound to be distilled. Therefore, in the present study, experimental VLE data pertaining to acetic acid and p-xylene pair has been generated at atmospheric pressure. The deviation of the

---

\* Author for correspondence; E-mail: ms.pavanmali@gmail.com

solution from an ideality has been determined by estimating activity coefficient using Wilson and NRTL models. An attempt has also been made to confirm thermodynamic consistency of experimental VLE data.

## EXPERIMENTAL

Acetic acid (99.8, W/V %) and para Xylene (99, W/V %) were purchased from Spectrochem and Loba Chemie, respectively. The Chemicals purchased was of highest purity available in the market and they were used without further processing.

### Analytical method

The mixtures were analyzed by the refractive index method, using ATAGO RX-7000i digital refractometer. The calibration curve was used for back calculation of the mole fractions of the components using the refractive index readings, the refractive index measurements were carried out at constant temperature 20°C. Fig. 1 shows the calibration curve.

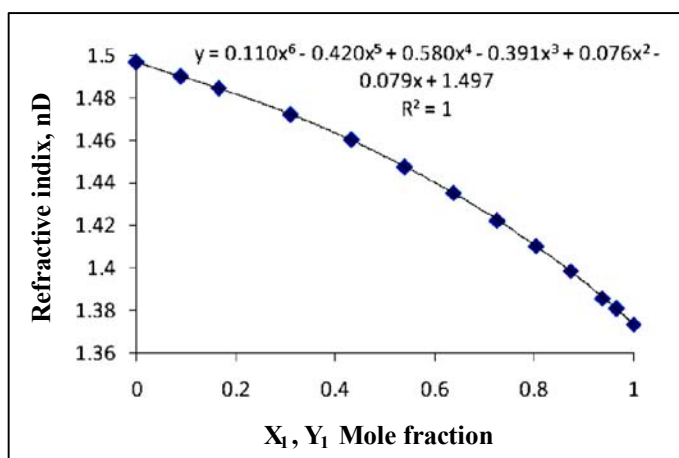

Fig. 1: Calibration curve

### Apparatus and experimental procedure

In this study, the VLE experiments were performed using a glass dynamic recalculating still apparatus<sup>3</sup>. The schematic representation is shown in Fig. 2.

The acetic acid and p-xylene pair of known concentration was introduced into the boiling chamber and the mixture was heated to reach equilibrium. The binary mixture in the boiling chamber starts to boil. After certain time the liquid recirculation starts. The liquid

mixture passes from the pores provided at the base of the innermost glass arrangement, as shown in the figure at point B. After getting heated up to certain range liquid goes for the recirculation. The liquid sample removal arrangement is provided at S1. Generation of the vapors starts as heating proceeds and the vapors are collected below the total condenser at point S2 as shown in the Fig. 2. Arrangement of the total condenser helps to collect the condensed vapors without escaping vapors to surrounding and further rise in temperature starts the recirculation of the vapors. After certain time span, at certain boiling point the temperature remains constant. This can be considered as equilibrium temperature. The equilibrium temperature is recorded at point right above the Cottrell pump. The temperature was measured with the help of Resistance Temperature Detector (RTD) thermometer.

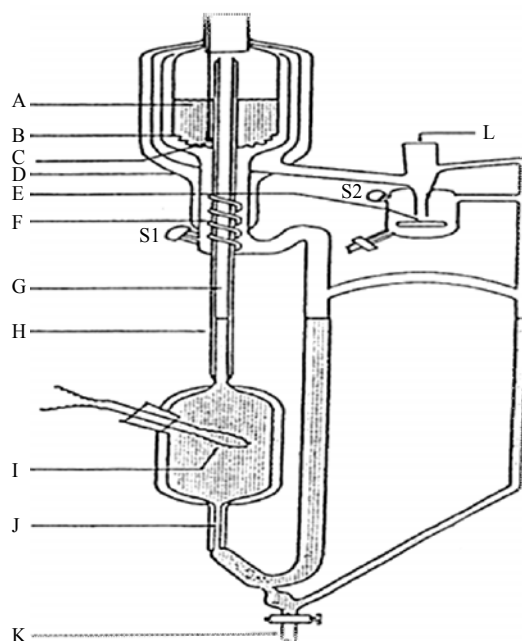

**Fig. 2: Experimental setup**

(A) Glass bed (B) Pores for liquid passage (C) Temperature (RTD) (D) Vacuum jacket  
 (E) Magnetic stirrer (F) Spiral coil (G) Cottrell pump (H) Jacket arrangement for cottrell pump  
 (I) Temperature measurement provision (K) Drain out (L) Total condenser arrangement,  
 S1- Liquid sample removal, S2- Vapor sample removal

The liquid phase sample is collected at point S1 and the vapor phase sample is collected at point S2. At the liquid sample collection side the coil arrangement is done for proper mixing of the liquid. At the vapor sample collection side an arrangement of magnetic stirrer is provided for proper mixing of the composition and good results.

## RESULTS AND DISCUSSION

The boiling point and refractive index in Table 1 shows the comparison between the experimental values and literature values. The values of Antoine constants are mentioned in Table 2. The data regression was done to calculate binary interaction parameters and also for calculated activity coefficients.

**Table 1: Properties of components**

S. No.	Name of chemical	Boiling point (°C) at atmospheric pressure		Density (Literature) g/cm <sup>3</sup>	Refractive index at 20°C		Mole. weight (g/mol)
		Literature	Expt.		Literature	Expt.	
1	Acetic acid	119	114.7	1.05	1.3717	1.3736	60.05
2	p-Xylene	138.4	132.2	0.861	1.495	1.4970	106.16

The equilibrium relationship can be expressed by following relationship is given by<sup>4,5</sup> –

$$y_i * \varphi_i^s * P = x_i * \varphi_i * \varphi_i^s * \exp \left\{ \frac{V_i^l (P_i - P_i^{\text{sat}})}{RT} \right\} \quad \dots(1)$$

Where P is total pressure and T is temperature in equilibrium system,  $P_i^{\text{sat}}$  is the saturation vapor pressure of pure component I, which can be obtained from the Antoine equation;  $y_i$  is the mole fraction of component i in the vapor phase;  $x_i$  is the mole fraction of component i in the liquid phase, R is the universal gas constant,  $V_i^l$  is the liquid mole volume of pure liquid i, calculated from the modified Rackett equation, and  $\gamma_i$  is the activity coefficient of component i. At low pressure, the exponential term in equation (1) is approximately equal to one, thus equation (1) can be simplified to

$$y_i * \varphi_i^v * P = x_i * \varphi_i * \varphi_i^s \quad \dots(2)$$

The activity coefficient of component i,  $\gamma_i$ , can be determined based on these equations.  $\gamma_i$  was also calculated by the solution models for the excess Gibbs energy, such as the Wilson, NRTL, and UNIQUAC models, and the relationship is –

$$\ln \gamma_i = \left\{ \frac{\left( \delta \left( \frac{nG^E}{RT} \right) \right)}{\delta n_i} \right\} \quad \dots(3)$$

**Table 2: Antoine constants values for the two components considered while calculations<sup>4</sup>**

S. No.	Component	A	B	C
1	Acetic acid	7.305	1481.961	217.078
2	p-Xylene	6.9905	1493.43	215.307

The equation used for the calculation is<sup>5</sup> –

$$\ln P_i^{\text{sat}} = A_i - \left( \frac{B_i}{T - C_i} \right) \quad \dots(4)$$

Where,  $P_i^{\text{sat}}$  is in (kPa), T is in ( $^{\circ}\text{C}$ )

**Table 3: Experimental Txy data and activity coefficients**

S. No.	T(K)	$x_1$	$y_1$	$\gamma_1$ (exp)	$\gamma_2$ (exp)	$\gamma_1$ (cal)	$\gamma_2$ (cal)
1	409.37	0.0000	0.0000	-	1.0007	-	1.0000
2	398.95	0.0743	0.3284	3.3084	0.9708	2.9120	1.0046
3	393.9	0.1354	0.4404	2.8269	1.0035	2.6650	1.0161
4	389.99	0.2235	0.5374	2.3532	1.0385	2.3356	1.0475
5	388.52	0.2888	0.5901	2.0924	1.0507	2.1168	1.0846
6	386.93	0.3988	0.6592	1.7786	1.0852	1.7992	1.1830
7	385.34	0.5116	0.6995	1.5465	1.2374	1.5356	1.3540
8	384.13	0.6141	0.7320	1.4009	1.4506	1.3437	1.6124
9	383.31	0.7286	0.7588	1.25644	1.9049	1.1785	2.1160
10	384.53	0.8214	0.7889	1.1145	2.4381	1.0814	2.8406
11	384.79	0.9270	0.8926	1.1082	3.0102	1.0148	4.4424
12	384.93	0.9626	0.9310	1.1082	3.7583	1.0040	5.3374
13	387.1	1.0000	1.0000	1.0703	-	1.0000	6.5466

By the help of data regression, we have found out the binary interaction parameters. Table 4 gives the detail about the binary interaction parameters.

**Table 4: Binary interaction parameters for Wilson and NRTL Models<sup>2,6</sup>**

S. No.	Binary parameters	WILSON	NRTL
1	$u_{12}-u_{11}$	3812.56	5478.37
2	$u_{12}-u_{22}$	6212.95	601.93
3	$\alpha$	-	0.3
4	$\Delta y_1$	0.01	0.01
5	$\Delta y_2$	0.01	0.01
6	$\Delta P$	1.339	1.2883

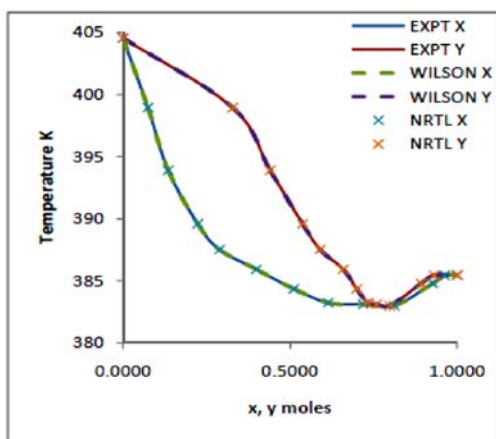
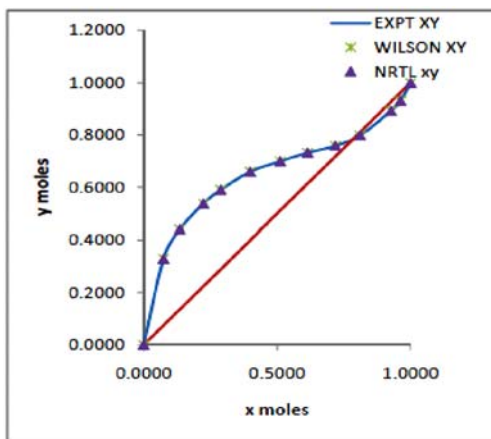
**Fig. 3: Txy Diagram for acetic acid and p-xylene Wilson and NRTL model fitting****Fig. 4: xy Diagram WILSON and NRTL model fitting**

## Consistency of data

### Area test

Experimental errors may cause deviation of the activity coefficients drawn from the experimental VLE data from the Gibbs Duhem equation. Therefore, the Herington method was used to check the thermodynamic consistency<sup>7</sup>. The data found was consistent by both area test and point to point test. The details of the consistency test are given below.

After rigorous procedure of model fitting, we have passed the data through the consistency test such as Herington's area test, which comes positive when the area above the curve equals the area below the curve. Followed by this test, we have used the point to point consistency test in which we have passed the criteria. According to this method the experimental data is thermodynamically consistent if, from  $\ln(\gamma_1/\gamma_2)$  v/s  $x_1$  plots the value of  $|D - J|$  is less than 10 and the values of  $D$  and  $J$  can be calculated using the equation (5) and (6). Where,  $S_1$  is area under curve above the x axis and  $S_2$  is area below the x axis under the curve.

$$D = 100 * \frac{(|S_1| - |S_2|)}{(|S_1| + |S_2|)} \quad \dots(5)$$

$$J = 150 * \left| \frac{(T^{\text{Max}} - T^{\text{Min}})}{T^{\text{Min}}} \right| \quad \dots(6)$$

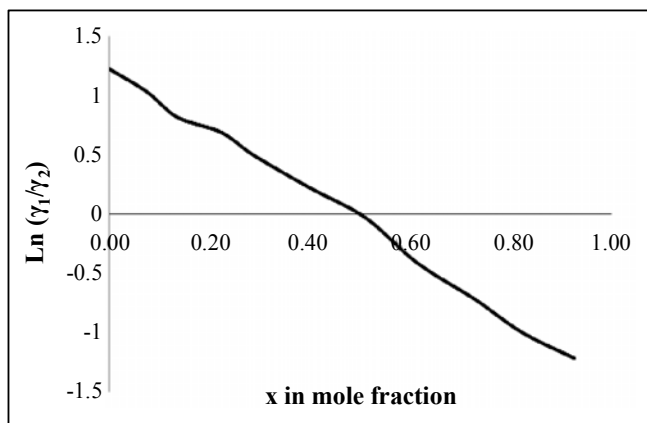

**Fig. 5: Consistency by area test**

### Point to point test

The vanness point to point test<sup>4</sup> calculates the average deviation between experimental

and calculated gas phase solute concentration ( $y_i$ ) of component  $i$  and system pressure ( $P$ ). The criteria for point to point test method are listed table below in this suitable activity coefficient model is used to calculate  $y_i$  and the total pressure  $P$ . First the activity coefficient model parameters are evaluated through regression with experimental VLE data. Suitable objective function is used to perform the regression average deviation calculated between experimental and model based calculated value<sup>7,8</sup>. A criterion for the data to be consistent is given in Table 5 below.

**Table 5: Criteria of consistency test for point to point method**

S. No.	Parameter	Formula	Criteria
1	Overall deviation in gas phase solute concentration	$\Delta Y = \frac{1}{N} * \sum_{j=1}^n [Y_i^{\text{cal}} - Y_i^{\text{exp}}]$	$\Delta Y_i \leq 0.01$
2	Overall deviation in total system pressure	$\Delta P = \frac{1}{N} * \sum_{j=1}^n [P_i^{\text{cal}} - P_i^{\text{exp}}]$	$\Delta P \leq 1.33$

In Table 5,  $J$  is the data number,  $N$  is the total number of the data points,  $y_{ij}^{\text{cal}}$  and  $y_{ij}^{\text{exp}}$  are the calculated and experimental vapor phase composition of species 'i' and 'p' cal and p exp are the calculated and experimental pressure of the system.

## CONCLUSION

Vapor liquid equilibrium data for binary mixture, acetic acid and p-xylene, is generated in this work. The activity coefficient calculation shows that the data is ideal up to 383.13 K temperature. The binary mixture conforms to non-ideality beyond temperature 383.13 K. It can be said that data is consistent as data passes area test and point to point test of consistency.

## REFERENCES

1. M. A. Joshep, D. Ramjugernath and J. D. Raal, Phase Equilibrium Properties of Binary System with Diacetyl from Computer Controlled Vapor Liquid Equilibrium Still, Fluid Phase Equilibria, **5**, 97-112 (1980).
2. N. A. M. Fadzil, M. H. Ab. Rahim and G. P. Maniam, A Brief Review of para Xylene Oxidation to Terepethalic Acid as Model of Primary C-H Bond Activation, Chinese J. Catal., **35**, 1641-1652 (2014).



3. D. G. Vorenberg, J. D. Raal and D. Ramjugernath, Vapor-Liquid Equilibrium Measurements of MTBE and TAME with Toluene, *J. Chem. Engg. Data*, **50**, 56-59 (2005).
4. O. P. Bagga and K. S. N. Raju, Isobaric Binary Vapor-Liquid Equilibria Systems Acetic Acid-Ethylbenzene and Acetic Acid-p-Xylene, *J. Chem. Engg. Data*, **15(4)**, 531-534 (1970).
5. J. M. Smith, H. C. Vaness and M. M. Abott, *Introduction to Chemical Engineering Thermodynamics*, Seventh Edition, Tata Mc-GrawHill (2006).
6. G. J. Hayden and J. P. O'Connell, A Generalized Method of Predicting the Second Viral Coefficient, *Indust. Engg. Chem. Proc. Design and Development*, **14**, 209-216 (1975).
7. T. Zhu, S. Yao, Z. Wang, W. Liu and H. Song, Isobaric Vapor Liquid Equilibria for the Binary and Ternary System of 2-Methyl-1-butanol, 2-Methyl-butanol Acetate and Dimethylformamide (DMF) at 101.325 kpa, *J. Chem. Engg. Data*, **58**, 1156-1160 (2013).
8. J. Wisniak, A. Apelblat and H. Segura, An Assessment of Thermodynamic Consistency Test for Vapor Liquid Equilibrium Data, *Phys. Chem. Liquids*, **35**, 1-58 (1997).

*Accepted : 21.06.2016*