



MICROBIOLOGICALLY INDUCED CORROSION SULFATE REDUCING BACTERIA IN STAINLESS STEEL AISI 316L

E. RUIZ, J. DUQUE and W. APERADOR*

School of Engineering, Universidad Militar Nueva Granada, BOGOTÁ-COLOMBIA

ABSTRACT

In this article, the behavior of microbiologically induced corrosion is studied by *Desulfovibrioaminophilus* in AISI 316L stainless steel. Bacterial characterization was conducted by macroscopic and microscopimorphological and biochemical tests. The growth kinetics is observed through periodic views; and electrochemical characterization by impedance diagrams and polarization curves Tafel. There cambiar results showed the growth of colonies in the surface material of variable and unstable take aggressive action of generating localized pitting, after the exposure time expolisacaridos matrix is generated, which reduces the corrosion rate in the sample of AISI 316 L.

Key words: *Desulfovibrioaminophilus*, Corrosion, Stainless Steel, Bacteria.

INTRODUCTION

Stainless steel is an alloy of iron and carbon containing by definition a minimum of 10.5% chromium, usually some types of stainless steel containing nickel and molybdenum as alloying elements¹. It has great advantages such as: corrosion resistance in acidic media and at elevated temperatures, ease in manufacturing due to its high degree of workability can be cut, welded, forged, high mechanical strength, that is why they are used in the food, chemical, pharmaceutical industries and medicine².

Stainless steels are classified by their crystalline structure in martensitic, ferritic, austenitic and austenitic have a greater number of available alloys such as nickel, manganese and nitrogen (200 series) and chrome-nickel (300 series), and are characterized by excellent formability, ductility, toughness, formability^{3,4}. The manganese, nickel and confer stability to the austenite phase in a wide temperature range, which prevents the transformation to martensite at the temperature change and the supplied chromium corrosion resistance and oxidation in extreme environments⁵⁻⁷.

* Author for correspondence; E-mail: g.ing.materiales@gmail.com

However, these steels are no strangers to chemical processes and suffer different types of corrosion: intergranular, pitting, low voltage, galvanic and microbiological. The latter caused by anaerobic bacteria, which generate a localized corrosive attack and generate an influence of erosion mechanisms which generates an effect of stress corrosion cracking and hydrogen embrittlement⁸.

In this article, the study of macroscopic, microscopic morphological characters, growth and affected by sulfate-reducing bacteria in austenitic steels was carried out.

EXPERIMENTAL

To determine the effect of sulphate reducing bacteria samples are prepared stainless steel AISI 316 L. The chemical composition of base material, obtained by analysis of X-ray fluorescence is presented in Table 1.

Table 1: Chemical composition of steel AISI 316L

Percentage	Compounds
18-20%	Cr
10-15%	Ni
2-3	Mo
2	Mn
0.75 %	Si
0.03	S
0.035	C
2	F

For preparation of the specimens were polished with sandpaper different from the number 80 to 1200 until leaving with a mirror-like luster, bacterial strains were extracted from a corrosive metal, which were grown by bacteriological to 37°C, pH 7.5 and in a culture medium with the composition as evidenced in Table 2^{9,10}.

The culture medium was prepared according wing NACE Standard TMO 194-2004, and distributed into Petri dishes¹¹. Subsequently the samples of AISI 316L were subjected to exposure of bacterial strains for 480 h incubation period at a temperature 37°C and pH 7.4.

Table 2: Culture medium composition

Percentage	Compounds
20 g	Pancreatic digest of casein
5 g	Sodium chloride
10 g	Dextrose
20 g	Agar
2 g	Sodium thioglycolate
1 g	Sodium formaldehyde sulfoxylate
2 mg	Methylene blue
1000 mL	Distilled water q.s.

For the characterization of bacterial Gram's method is used for observation of microscopic morphological and gender of the strain was confirmed by biochemical tests: Catalase by means of a drop of H₂O₂, oxidase Bactident strips of Merck, for the fermentation of carbohydrates by phenol red, the hydrogenase and hydrogenase Caprocode sulfuviridina test kit was used in a liquid medium postage and added a drop of 2N NaOH¹².

To study the kinetics of growth of sulphate-reducing bacteria, monitoring for a period of 480 hrs of incubation where regular measurements were taken every 24 hrs to identify the phases of bacterial growth, by a direct method performed the cell dry weight and the counting the number of cells¹².

Counting of the number of cells was performed by using the Petroff-Hausser. Camera has a grid is divided into 25 fields recorded on the bottom of the chamber. Each of the fields is subdivided in a grid of 16 squares^{13,14}. It was used phase contrast microscope with a 40X objective for counting bacteria in only 5 of the 25 fields¹⁵. It can calculate the number of microorganisms in a sample, from the volume of the chamber and sample dilutions necessary. The equation (1) used for this determination was¹⁶:

$$\frac{\text{Number of bacteria}}{\text{mL}} = \frac{\Sigma \text{ Cells counted in the fields}}{4} \times \frac{1}{\text{Dilution}} \times 10^6 \quad \dots(1)$$

Electrochemical techniques were performed according to ASTM G1 and G3 regarding electrochemical tests. All the electrochemical tests were performed with parameters of time 306, 408 and 480 h incubation of Sulphate-reducing bacteria in order to establish the bacterial growth in each sample and the wear caused to the steel surface¹⁷.

The electrochemical tests were performed in a Gamry model computer PCI 4, at room temperature. The immersion of the samples were made immersing the samples and it is performed in a solution containing 3.5 wt% sodium chloride analytical. The type of reference electrode used in all tests was an electrode of Ag/AgCl of type analytical electrochemistry BAS (MF-2052 RE-5B), which has a potential of +0,194 V with respect to reference electrode hydrogen room temperature. All potentials are referred to the potential of the electrode Ag/AgCl^{18,19}. In potentiostatic and impedance spectroscopy tests, a platinum counter electrode was used. The Nyquist diagrams were obtained with frequency sweeps between 100 kHz and 0.001 Hz using a sinusoidal signal amplitude of 10 mV and exposed area of 1 cm². Tafel plots were obtained at a scan rate of 0.5 mV/s in a range of voltages from -0.25 V to 1V. The working temperature of the trials was room temperature, with a controlled oscillation $\pm 0.1^{\circ}\text{C}^{18}$. To avoid contamination of the working environment, the specimens and the electrodes used were cleaned with acetone by ultrasound then with 98% ethyl alcohol to remove bacterial debris.

RESULTS AND DISCUSSION

Bacterial characterization

As macroscopic morphological characters are recorded two colonies characterized by a round shape, whole edge, dark gray (mature colony) and purple (young colony), smooth surface, medium punctate as to the microscopic features are observed bacillus straights gram negatives disposition in singles or pairs.

Biochemical characterization

In Table 3, the results of biochemical tests on each of the strains worked are presented.

Table 3: Results of biochemical tests

Test	Bologna 1	Bologna
Catalase	+	+
Oxidase	-	-
Fermentation of carbohydrates	-	-
Hydrogenase	+	+
Desulfuviridina	+	+

Considering morphological characteristics and the results of the biochemical tests and compared as described in the manual Bergeys by macroscopic and microscopic polymorphic characters, the presence of the enzyme desulfuviridina that is responsible synthesis of sulfur in energetic processes. It can evidence that the colonies belong to the species *Desulfovibrioaminophilus*¹⁹.

Studies by Videla 2002, 2004 on the role of sulphate-reducing bacteria biocorrosion processes, inferred that the metabolic products react with carbon causing wear on the surface of the material generating a layer that produces pitting corrosion on the surface of the material²⁰. Since the bacteria generate a defense mechanism against external agents on the surface of the metal and facilitate the accumulation of organic and inorganic substances necessary for growth²¹.

Growth kinetics

In Fig. 1, the growth of *Desulfovibrioaminophilus* in AISI 316 L steel is observed, a variable growth and an unstable trend in terms of growth rate. The first adaptation phase starts at 144 h of incubation where the pH decreases to 7. The second step or stage of exponential growth begins at 240 h wherein the surface is yellowish and starts to form oxide layers on the material surface, during this period the pH decreases to 6.5, the growth is not constant.

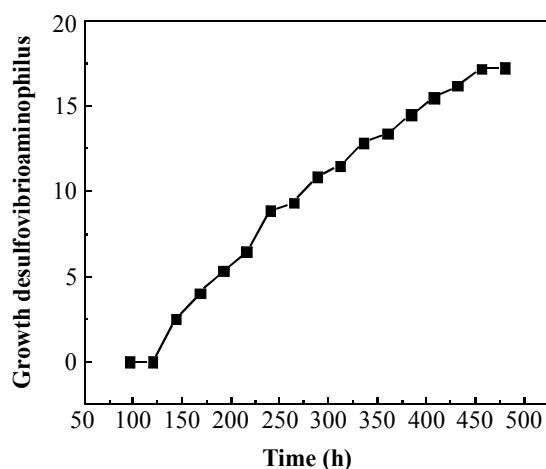

Fig. 1: Growth kinetics of *Desulfovibrioaminophilus* steel AISI 316

It presents fluctuations between 264 and 288 h are appreciated because the pH reached 7.0, which caused the level of the bacterial population decreases dramatically, the stage between 288 and 480 h is exponential where most corrosion rate and a exopolysac

chride matrix on the surface, which is characterized by a high level of adhesion is observed²². At this stage the bacteria, through hydrogenase enzyme, begins cathodic depolarization at the material surface and occurs the fragmentation of the protective chromium oxide layer and the result is a bites into the material surface. The plateau stage increases the pitting and bacterial metabolism has reached a constant balance²².

Electrochemical characterization

In impedance diagrams of Fig. 2, observed that the behaviour of films. It has a different behaviour in each time evaluated. The polarization resistance or resistance to charge transfer to the oxide films was calculated with the sum of the resistance of the porous layer and the resistance of the barrier layer. For the sample evaluated to 306 hrs, presented a resistance to the transfer of charge has a value of 0.43 kohm, The resistance to charge transfer of the films obtained times 406 and 480 h presented a significant increase of 63.78 kohm values and 129.44 kohm, respectively, It was observed that the resistance, which opposes the load step is the film of chromium oxide. The significant variation of resistance to the passage of load is because the thickness of the grown layer increases with evaluation time. It can be seen that there is a variation of the capacitance of the porous layers and barrier (C_c and C_{corr}) in function the time spent in obtaining films, this is due to variations in thickness (porous layer)²³.

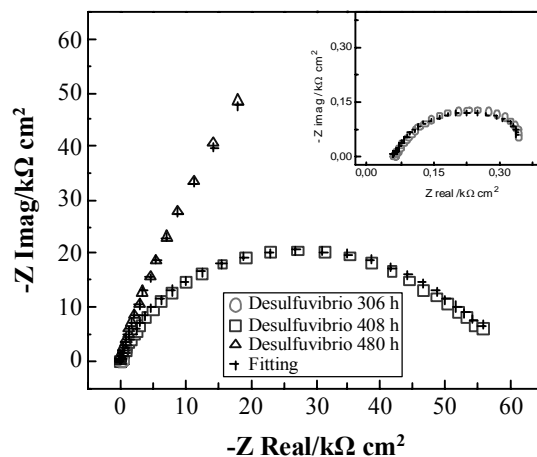

Fig. 2: Diagram for the study of the reaction of the bacterium *Desulfovibrioaminophilus* evaluated versus time Nyquist

The interpretation of the data was obtained. It requires the modeling of an analogous electrical circuit the physical system studied, also called equivalent circuit, the model that provided the best fit was presented in Fig. 3. The equivalent circuit has two sets of elements

of constant phase and is due to the presence of a layer of passivating surface oxide (barrier layer), and a second porous layer²⁴.

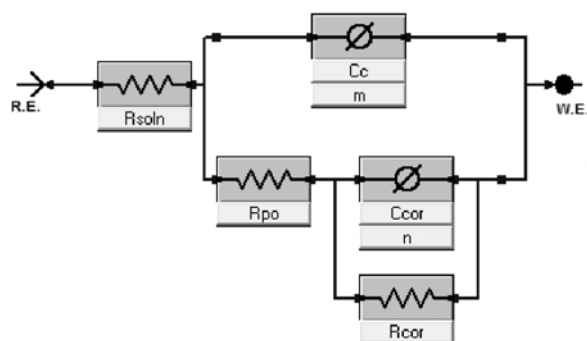

Fig. 3: The equivalent circuit corresponding to the evaluation of steel and presence of *Desulfivibrioaminophilus* in Function of time

In Fig. 4, the main parameter calculated through of the Tafel polarization curves was obtained and it is the corrosion rate of the formed films. It is established that the film with lower corrosion rate. It is evaluated 480 h with a value of 0.17 mpy (Table 4), and that corrosion rate higher what we get is the tests performed on the substrate evaluated to 306 h. One can conclude that with increasing time to value decreases the rate of corrosion^{25,26}.

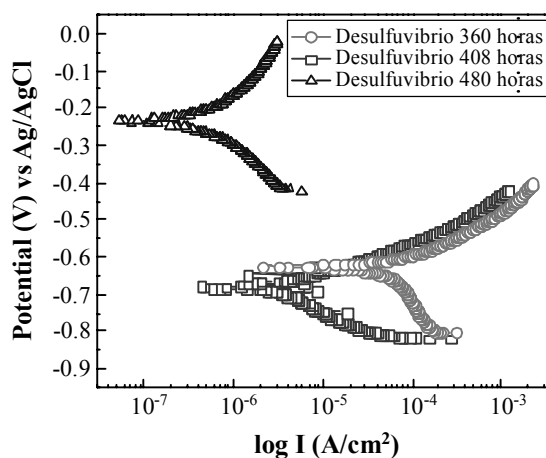

Fig. 4: Cathodic polarization curves corresponding to bacteria *Desulfivibrioaminophilus* evaluated at different times of evaluation

These results of electrochemical tests indicates that the film obtained at 480 h presents better properties anticorrosion; and reflects more deterioration and less anticorrosion

properties the film obtained 306 h. All these properties of corrosion protection is directly related to the thickness of the aluminum oxide films, as well as the pore density presented by each coating, as discussed below.

Table 4: Parameters obtained from the Tafel polarization curves for the steel exposed to the bacteria *Desulfuvibrioaminophillus* in different time ranges

<i>Desulfuvibrioaminophillus</i>	360 h	408 h	480 h
Pending cathodic V/dec	-96.66m	-119.99m	-321.92m
Pending anodic V/dec	91.22m	69.35m	99.49m
Corrosion voltage /V	-0.62	-0.68	-0.23
Corrosion current uA/cm ²	70.09	7.23	0.62
Corrosion rate/mpy	101.88	2.35	0.17

The formation of bacterial niches on metals is the result of a cumulative process, which begins as to the individuals establish a microhabitat in the material surface; thereby forming a thin film due to deposition of ions and organic compounds, that affects electrostatic charge facilitate bacterial colonization.

According to the graph of growth, it occurs in a short time and leads to the production of a exopolysaccharide matrix resulting in the development of a mature biofilm, which becomes a dynamic system in which are performed the processes transport and chemical reactions transport processes and chemical reactions wearing surface material wearing the material surface. Microbial activity formed on steel AISI 316 L can affect the cathodic reactions and /or anodics which modify significantly chemistry of the material being accelerated the corrosive layer²⁷.

The number of cells of *Desulfovibrioaminophillus* has a variable growth and unstable attack of form localized and using H₂ as the electron donor; the sulphate generated for the individuals is used in metabolic processes as electron acceptor and CO₂ as sole carbon source.

CONCLUSION

The AISI 316L stainless steel inside their compounds have the necessary elements for the crecimeinto of *Desulfuvibrioaminophillus* and its growth is moderate and unstable considering the polarization curves. Tafel and growth kinetics of the species is evident for the relation directly proportional about bacterial growth and passivation process

ACKNOWLEDGEMENT

This research was supported by "Vicerrectoría de investigaciones de la Universidad Militar Nueva Granada" under contract ING 1908.

REFERENCES

1. R. Mendes, J. B. Ribeiro and A. Loureiro, *Mater. Des.*, **51**, 182 (2013).
2. S. Lozano-Perez, T. Yamada, T. Terachi, M. Schröder, C. A. English, G. D. W. Smith, C. R. M. Grovenor and B. L. Eyre, *Acta Mater.*, **57**, 5361 (2009).
3. E. O. Olakanmi, R. F. Cochrane, K. W. Dalgarno, *Prog. Mater. Sci.*, **74**, 401 (2015).
4. S. García-Rodríguez, A. J. López, B. Torres and J. Rams, *Surf. Coat. Technol.*, **287**, 9 (2016).
5. I. Arrayago, E. Real and E. Mirambell, *Thin Walled Struct.*, **100**, 93 (2016).
6. R. Maestracci, A. Sova, M. Jeandin, J.-M. Malhaire, I. Movchan, Ph. Bertrand and I. Smurov, *Surf. Coat. Technol.*, **287**, 1 (2016).
7. G. V. Prasad Reddy, R. Kannan, K. Mariappan, R. Sandhya, S. Sankaran and K. Bhanu Sankara Rao, *Int. J. Fatigue*, **81**, 299 (2015).
8. H. X. Yuan, Y. Q. Wang, L. Gardner, X. X. Du and Y. J. Shi, *J. Constr. Steel Res.*, **111**, 75 (2015).
9. H. Y. Yi, F. K. Yan, N. R. Tao and K. Lu, *Scr. Mater.*, **114**, 133 (2016).
10. L. Mosecker, D. T. Pierce, A. Schwedt, M. Beighmohamadi, J. Mayer, W. Bleck and J. E. Wittig, *642, Mater. Sci. Eng.*, **A642**, 71 (2015).
11. Z. B. Zheng and Y. G. Zheng, *Corros. Sci.*, **102**, 259 (2016).
12. C. Pascal, V. Parry, E. Fedorova, M. Braccini, P. Chemelle, N. Meyer, D. Oquab, D. Monceau, Y. Wouters and M. Mantel, *Corros. Sci.*, **93**, 100 (2015).
13. P. Krakhmalev, I. Yadroitsava, G. Fredriksson and I. Yadroitsev, *Mater. Des.*, **87**, 380 (2015).
14. N. Mazinianian, I. Odnevall Wallinder and Y. Hedberg, *J. Food Eng.*, **145**, 51 (2015).
15. D. P. Mondal, Hemant Jain, S. Das and A. K. Jha, *Mater. Des.*, **88**, 430 (2015).
16. I. S. Molchan, G. E. Thompson, J. Walton, P. Skeldon, A. Tempez and S. Legendre, *Appl. Surf. Sci.*, **357**, 37 (2015).

17. P. Craidy, L. Briottet and D. Santos, *Int. J. Hydrogen Energy*, **40**, 17084 (2015).
18. S. Liu, Z. Liu, Y. Wang and J. Tang, *Corros. Sci.*, **83**, 396 (2014).
19. F. H. Abed, S. I. Ranganathan and M. A. Serry, *Mech. Mater.*, **77**, 142 (2014).
20. N. Das, G. Abraham, P. Sengupta, Ashok Arya, V. Kain and G. K. Dey, *J. Nucl. Mater.*, **467**, 489 (2015).
21. C. Chandrasatheesh, J. Jayapriya, R. P. George and U. Kamachi Mudali, *Eng. Fail. Anal.*, **42**, 133 (2014).
22. E. Huttunen-Saarivirta, M. Honkanen, T. Lepistö, V.-T. Kuokkala, L. Koivisto and C.-G. Berg, *Appl. Surf. Sci.*, **258**, 6512 (2012).
23. S. J. Yuan and S. O. Pehkonen, *Colloids Surf., B*, **59**, 87 (2007).
24. A. B. Cristóbal, M. A. Arenas, A. Conde and J. de Damborenea, *Electrochim. Acta*, **52**, 546 (2006).
25. M. Moradi, J. Duan, H. Ashassi-Sorkhabi and X. Luan, *Corros. Sci.*, **53**, 4282 (2011).
26. R. Javaherdashti, R. K. Singh Raman, C. Panter, E. V. Pereloma, *Int. Biodeterior. Biodegrad.*, **58**, 27 (2006).
27. P. J. Antony, R. K. Singh Raman, R. Raman and Pradeep Kumar, *Corros. Sci.*, **52**, 1404 (2010).

Revised : 05.02.2016

Accepted : 08.02.2016