



# **LOW VOLUME CHEMICAL DISPENSER FOR AUTOMATIC TITRATION**

**P. SUBRAMANIAN<sup>\*</sup>, MOTI KUMARI and PRIYANKA KUMARI**

ECE Department, Aarupadai Veedu Institute of Technology,  
CHENNAI (T.N.) INDIA

## **ABSTRACT**

In titration, a known solution called the titrant is added to an unknown solution called the analyte till reaction gets completed. The determination of the end point is crucial as also the quantity of the titrant used. Here we discuss a low volume chemical dispenser for automatic titration. The purpose is to develop an accurate dispenser as well as an automatic system that can be employed in hazardous environments.

**Key words:** Titration, Dispenser.

## **INTRODUCTION**

Titration is a process wherein a chemical called titrant is added in small steps to an unknown solution called the analyte until the reaction stops. The end point determination is much crucial in determining the accuracy of the result. Environmental studies, Chemical studies, Pharmaceutical studies all involve titration and need accurate dispensation of chemicals to analyze the results. Dispensation of hazardous chemicals needs automatic systems wherein the exact levels of chemicals are dispensed. Wastage of rare chemicals is also avoided by this automation

### **System blocks**

The system consists of a syringe driven by a stepper motor. The stepper is driven and controlled by commands that can be programmed and transmitted through a suitable interface between the computer and the motor driver.

### **Interface**

An interface is needed between the computer and the motor driver. The UM245R, by

---

<sup>\*</sup> Author for correspondence; E-mail: subramanian@avit.ac.in

Future Technology Devices International Ltd, is a development module that is a single chip USB to parallel FIFO bidirectional data transfer interface. It provides a simple interface with four-wire handshake. It does not require USB-specific firmware programming. It can also provide data transfer rate of up to one Mbps. The onboard socket available helps in connecting the module directly to a personal computer through a standard USB cable. The figure 1 shows the UM245R and figure 2 shows the pin diagram of UM245R.

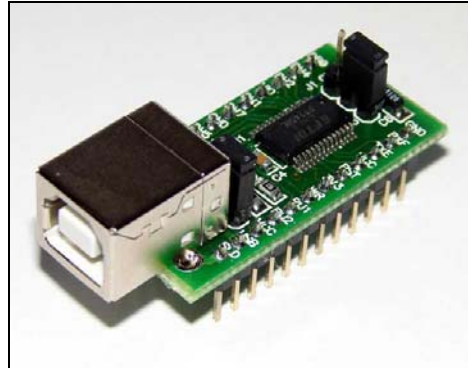

**Fig. 1: UM245R**

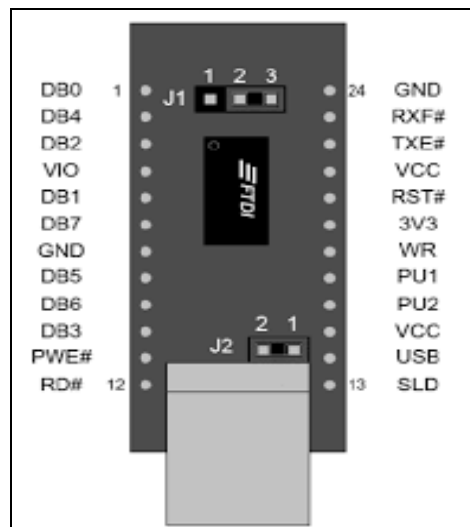

**Fig. 2: Pin diagram of UM245R**

### Motor driver

The stepper motor used to move the syringe is to be controlled through a driver. The L293D is a quadruple high current half-H driver by Texas Instruments. The L293D can

provide bidirectional drive currents upto 600mA with voltages from 4.5V to 36V. This is used to drive the stepper motor.

### Stepper motor

The stepper motor is used to push and pull the plunger of the syringe. The circular motion of motor shaft can be converted to linear motion of the plunger, with clockwise rotation translated to push and anticlockwise rotation to pull.

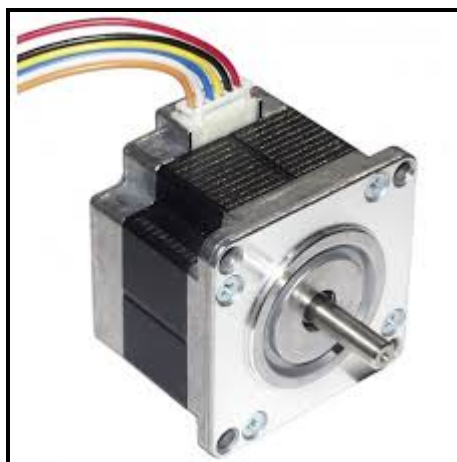

**Fig. 3: Stepper motor**

### Algorithm

1. Initialise interface module
2. Initialise motor for adjusting the syringe position
3. Get step volume, mixing time and maximum volume from user
4. Inject step volume by actuating the syringe piston using stepper motor
5. Wait for mixing time interval
6. Read sensor values and display
7. Check for user interrupt to quit else go to step 4.

### EXPERIMENTAL

The testing was carried out with a fixed inject volume and mixing time. The measured volume is close to the inject volume.

**Table 1 : Experimental results injected Vs measured volume**

<b>Inject volume <math>\mu\text{L}</math></b>	<b>Measured volume <math>\mu\text{L}</math></b>
120	139.6
460	487
640	669

### **CONCLUSION**

The injection of correct volume of the chemical plays an important role in many processes. This work can be extended to any application to reduce wastage, improve quality and avoid contact with hazardous materials.

### **REFERENCES**

1. [www.ftdichip.com](http://www.ftdichip.com)
2. [www.ti.com](http://www.ti.com)
3. David White, Kenn Scribner and Eugene Olafsen, MFC Programming with Visual C++6 Unleashed with CDROM, SAMS (1999).

*Accepted : 11.10.2016*